

## Model Type UFLT

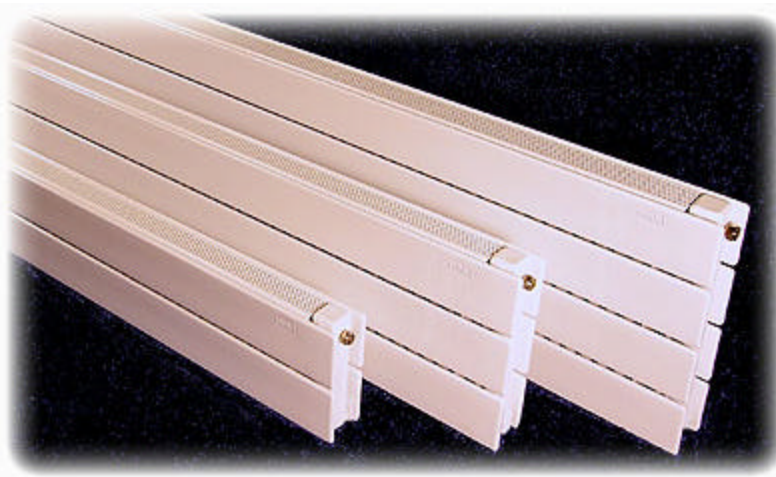

### SPECIFICATIONS



UFLT-2

UFLT panel radiators are manufactured in the USA from cold rolled steel. The panels are finished in gloss powdercoat and available in many standard colors and over 100 optional colors. These panels are made in lengths from 2'-0" to 14'-0", and heights from 5 7/8" to 14 3/8". Standard piping connections are 1/2" NPT for inlet and outlet piping, and 1/8" NPT for vents. For more complete UFLT specifications, please refer to the Runtal technical pages.

### BTUH/FT RATINGS

Energy efficient as well as space saving. The UFLT combines the output of a UF radiator with an inactive front panel, making the UFLT perfect for spanning window mullions or where a lower temperature front face is desired. Various average water temperatures (AWT) are shown here for convenience, but for more specific conditions use the appropriate correction factor with the 215°F rating. Please see the technical pages for the correction factor best suited to the design conditions.

BTUH/ft Ratings @ 65°F EAT					
MODEL	HEIGHT inches	DEPTH inches	215°F	180°F	140°F
UFLT-2	5.7	1.6	867	610	349
UFLT-3	8.6	1.6	1118	787	451
UFLT-4	11.5	1.6	1351	951	544
UFLT-5	14.4	1.6	1718	1209	692

### MOUNTING SYSTEMS

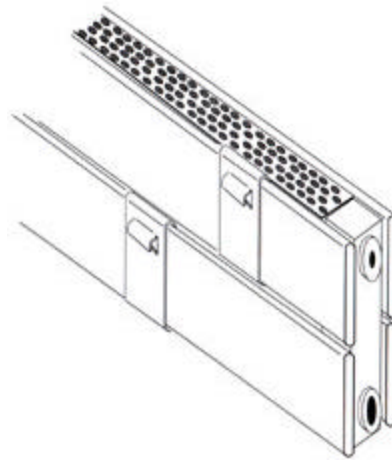
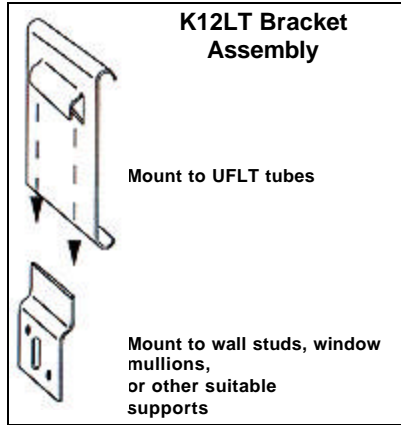

**UFLT-2**